

JANUARY 2002

EXAMINATION

MATHEMATICS

Paper 02 - General Proficiency

2 hours 40 minutes

03 JANUARY 2002 (a.m.)

INSTRUCTIONS TO CANDIDATES

1. Answer ALL questions in Section I, and any TWO in Section II.
2. Begin the answer for EACH question on a new page.
3. Full marks may not be awarded unless full working or explanation is shown with the answer.
4. Mathematical tables, formulae and graph paper are provided.
5. Silent electronic calculators may be used for this paper.
6. You are advised to use the first 10 minutes of the examination time to read through this paper. Writing may begin during this 10-minute period.

DO NOT TURN THIS PAGE UNTIL YOU ARE TOLD TO DO SO

SECTION I

Answer ALL the questions in this section.

All working must be clearly shown.

1. (a) Calculate the exact value of

$$1\frac{2}{3} + \left(2\frac{1}{8} \div \frac{3}{4}\right)$$

giving the answer as a fraction in its lowest terms. (4 marks)

- (b) Mr Jones works for a basic wage of \$15 per hour for a 40-hour week.

- (i) If Mr Jones worked only 40 hours during a particular week, what was his wage for that week? (2 marks)
- (ii) Mr Jones' wage for the next week was \$960. If overtime is paid at double time, how many hours overtime did he work? (4 marks)

Total 10 marks

2. (a) If $a = 4$, $b = -2$ and $c = 3$, calculate the value of

$$\frac{a(b - c)}{bc}$$

(2 marks)

- (b) Factorize completely

$$3pq + q + 6p + 2.$$

(2 marks)

- (c) Simplify

(i) $\frac{4c^2 \times 3c^4}{c^3}$

- (ii) $2(3x + 1) - (x + 2).$ (4 marks)

- (d) Solve simultaneously

$$2x + 3y = 11$$

$$4x + 2y = 10.$$

(4 marks)

Total 12 marks

3. (a) Given that $A = \begin{pmatrix} 2 & 1 \\ 0 & -1 \end{pmatrix}$ and $B = \begin{pmatrix} -1 & 1 \\ 1 & 2 \end{pmatrix}$,
calculate

(i) $A + 2B$

(ii) B^2 .

(5 marks)

- (b) A survey conducted among a group of 50 students showed that
30 students played football
9 students played cricket and football
 x students played neither cricket nor football
 $3x$ students played cricket only.

(i) Draw a clearly labelled Venn diagram to illustrate the information above.

(ii) Determine the number of students who played cricket.

(6 marks)

Total 11 marks

4. (a) (i) **Using ruler and compasses only**, construct triangle PQR with $QR = 6.5$ cm,
 $PQ = 8.0$ cm and angle $PQR = 75^\circ$.
- (ii) Measure PR and state its length, in cm.
[All construction lines must be clearly shown.]

(5 marks)

(b)

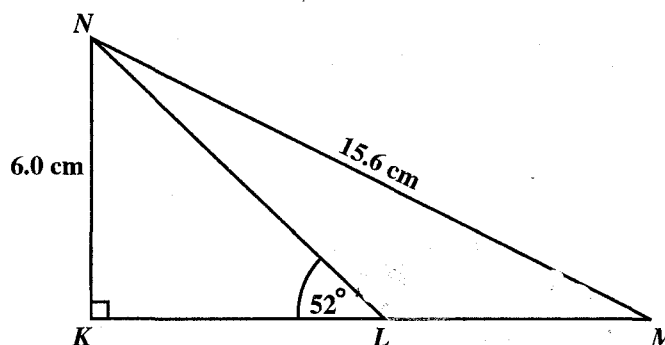

In the diagram above, **not drawn to scale**, $KN = 6.0$ cm, $MN = 15.6$ cm, angle $MKN = 90^\circ$, angle $KLN = 52^\circ$ and KLM is a straight line.

Calculate, giving the answer to 1 decimal place

(i) the size of angle KMN

(ii) the length of LM , in cm.

(7 marks)

Total 12 marks

5. (a) Given that $f(x) = 9 - x$, and $g(x) = x^2$,
calculate

(i) $f(3)$

(ii) $g(-4)$

(iii) $fg(2)$.

(4 marks)

(b)

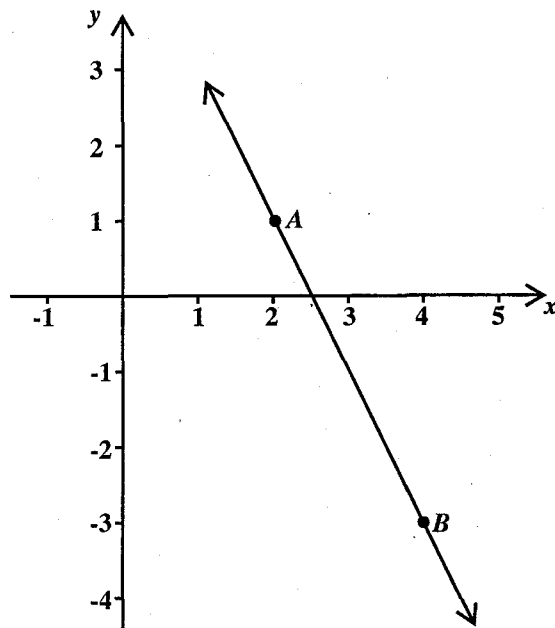

The diagram above, **not drawn to scale**, shows the line AB passing through the points $A(2, 1)$ and $B(4, -3)$.

- (i) Calculate the gradient of the line AB .

- (ii) Write the equation of the line AB .

(4 marks)

(c) CD is a line parallel to AB and passes through the origin.

- (i) Write the equation of the line CD .

- (ii) Calculate the gradient of a line perpendicular to CD .

(3 marks)

Total 11 marks

6. (a) A bus left Town A at 09:05 hours and travelled to Town B, 48 km away, at an average speed of 80 km h^{-1} .

(i) At what time did the bus arrive at Town B?

On its return journey, the bus took 45 minutes to travel from Town B to Town A.

Calculate the average speed of the bus, in km h^{-1} , for

- (ii) the return journey from Town B to Town A
 (iii) the entire journey, giving your answer correct to 3 significant figures.

(7 marks)

(b)

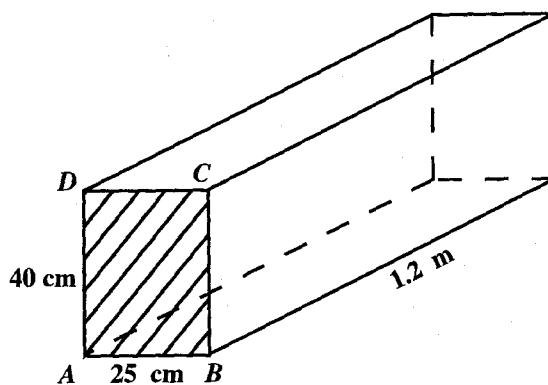

The diagram above, **not drawn to scale**, shows a water tank in the shape of a right prism. $AB = 25 \text{ cm}$, $AD = 40 \text{ cm}$ and the length of the tank is 1.2 m .

Calculate

- (i) the volume, in cm^3 , of the tank
 (ii) the depth of water in the tank when it contains 45 litres of water.

(5 marks)

Total 12 marks

7. The table below shows the frequency distribution of the marks obtained by 100 students in a test.

Marks	Number of students	Cumulative Frequency
1 – 5	4	4
6 – 10	6	
11 – 15	12	
16 – 20	20	
21 – 25	26	
26 – 30	16	
31 – 35	11	
36 – 40	5	

- (a) Complete the cumulative frequency table to represent the data. (1 mark)
- (b) Using a scale of 2 cm to represent 5 marks on the horizontal axis and 1 cm to represent 5 students on the vertical axis, draw the cumulative frequency curve for the data. (6 marks)
- (c) (i) From the cumulative frequency curve, determine the number of students who scored at least 24 marks on the test.
- (ii) Show, by drawing lines on your graph, how you obtained your answer. (3 marks)

Total 10 marks

8. (a) If $a * b = (a - b)^2$, calculate
- (i) $2 * 5$
- (ii) $(5 * 2) * 4$. (3 marks)
- (b) Show that the operation $*$ is commutative. (1 mark)
- (c) Determine the range of values of x for which $x - 3 \leq 2x - 8$. (2 marks)

(d)

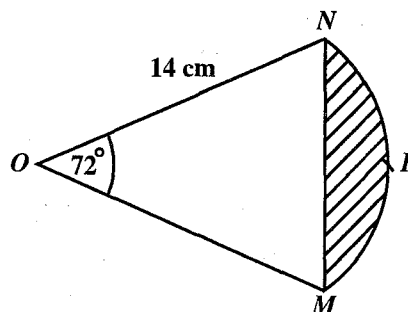
[Take π to be 3.14.]

In the diagram above, **not drawn to scale**, $MPNO$ is the sector of a circle, with centre O and radius 14 cm. Angle MON is 72° .

Calculate, to 1 decimal place, the area of

- (i) triangle OMN
- (ii) the shaded region bounded by the chord MN and the arc MPN . (6 marks)

Total 12 marks**SECTION II**

Answer **TWO** questions in this section.

RELATIONS AND FUNCTIONS

9. (a) (i) Write $f(x) = 3x^2 - 12x + 5$, in the form $f(x) = a(x + b)^2 + c$, where a , b and c are constants.

Hence, determine for $f(x) = 3x^2 - 12x + 5$

- (ii) the minimum value of $f(x)$
 - (iii) the coordinates of the minimum point on its graph. (7 marks)
- (b) A motorist starting from rest accelerates uniformly to a speed of 50 km h^{-1} in 30 minutes. He continues at this speed for another 2 hours. He then accelerates uniformly for another 90 minutes until he reaches a speed of 80 km h^{-1} .
- (i) Using a scale of 2 cm to represent 1 hour on the horizontal axis and 2 cm to represent 10 km h^{-1} on the vertical axis, draw a velocity-time graph to show the journey of the motorist.

Using the graph, determine

- (ii) the acceleration, in km h^{-2} , during the last 90 minutes
- (iii) the distance travelled in the first two and a half hours. (8 marks)

Total 15 marks

10. (a) A boy wants to buy x ties and y shirts.
He must buy at least 2 but no more than 6 ties.
- (i) Write an inequality to represent this information.
- He must buy at least one shirt.
- (ii) Write an inequality to represent this information.
- The boy has \$196 to buy ties and shirts. A tie costs \$14 and a shirt costs \$28.
- (iii) Write an inequality to represent this information. (4 marks)
- (b) Using a scale of 1 cm to represent 1 unit on both axes, draw the graphs of the inequalities written in 10 a (i), (ii) and (iii) above.
Shade the region that satisfies these inequalities. (6 marks)
- (c) The boy sells the shirts and ties to make a profit of \$5 on each tie and \$8 on each shirt.
- (i) Write an expression to represent his total profit, P .
- (ii) Use your graph to determine the number of shirts and ties that he must buy to obtain the maximum profit.
- (iii) Calculate the maximum profit. (5 marks)

Total 15 marks

GEOMETRY AND TRIGONOMETRY

11. (a) Prove that
- $$\frac{1}{1 - \sin^2 x} - 1 = \tan^2 x \text{ for all values of } x. \quad (4 \text{ marks})$$
- (b) A ship leaves a harbour, H , and sails to a port, A , 45 km away on a bearing of 064° . The ship then changes course and sails to another port, B , 60 km away on a bearing of 285° .
- (i) Sketch the ship's journey, clearly showing
- the north direction
 - the bearings 064° and 285°
 - the points H , A and B .
- Calculate
- (ii) the distance HB , in km, to 2 decimal places
- (iii) the bearing of H from B , to the nearest degree. (11 marks)

Total 15 marks

GO ON TO THE NEXT PAGE

12. (a)

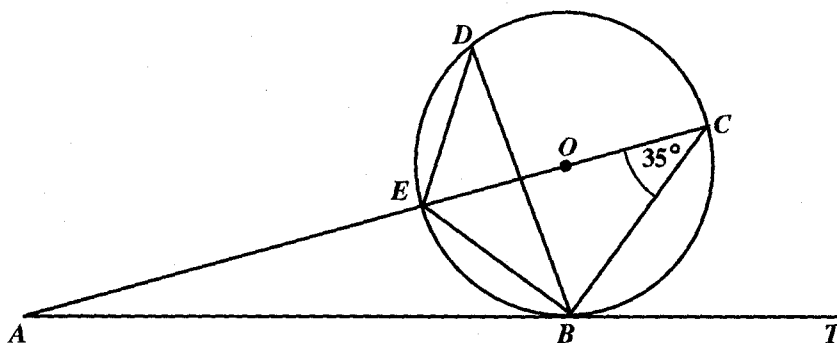

In the diagram above, **not drawn to scale**, ABT is a tangent to the circle $BEDC$, centre O . AEC is a straight line through the centre O , with angle $\hat{ECB} = 35^\circ$.

Calculate, giving reasons for your answers, the sizes of the following angles:

(i) \hat{EDB}

(ii) \hat{BEC}

(iii) \hat{CBT}

(iv) \hat{BAE}

(8 marks)

(b) [For this question, use $\pi = 3.14$ and $R = 6\,370$ km]

Three towns, P , Q and R are situated at $(50^\circ\text{S}, 15^\circ\text{W})$, $(0^\circ, 15^\circ\text{W})$ and $(0^\circ, x^\circ\text{E})$ respectively.

(i) Calculate, to the nearest kilometre, the distance PQ , measured along the common line of longitude.

(ii) The distance QR , measured along the equator, is 3 570 km. Calculate, to the nearest degree, the value of x .

(7 marks)

Total 15 marks

VECTORS AND MATRICES

13. (a) Find the values of x for which the matrix $P = \begin{pmatrix} 3x & 4 \\ 6x & x \end{pmatrix}$ is a singular matrix. (4 marks)
- (b) If $M = \begin{pmatrix} 3 & 4 \\ 2 & 1 \end{pmatrix}$
calculate
- (i) the determinant of M
- (ii) M^{-1} .
- (c) Hence, calculate the values of x and y , which satisfy the simultaneous equations
- $$\begin{aligned} 1.5x + 2y - 5 &= 0 \\ 4x + 2y - 10 &= 0. \end{aligned}$$
- (11 marks)

Total 15 marks

14. $WXYZ$ is a **parallelogram**. The position vectors of W , X and Y are $\begin{pmatrix} 2 \\ 1 \end{pmatrix}$, $\begin{pmatrix} 6 \\ 3 \end{pmatrix}$ and $\begin{pmatrix} 4 \\ 7 \end{pmatrix}$ respectively.
- (a) Determine in the form $\begin{pmatrix} x \\ y \end{pmatrix}$, the vectors
- (i) \vec{WX}
- (ii) \vec{XY}
- (iii) \vec{WZ}
- (iv) \vec{OZ} . (6 marks)
- (b) M is the midpoint of WY and N is the midpoint of XZ .
Show by a vector method that
- (i) $\vec{OM} = \vec{ON}$
- (ii) $|\vec{WX}| = |\vec{XY}|$. (8 marks)
- (d) Describe fully, the shape of the figure $WXYZ$. (1 mark)

Total 15 marks

END OF TEST